

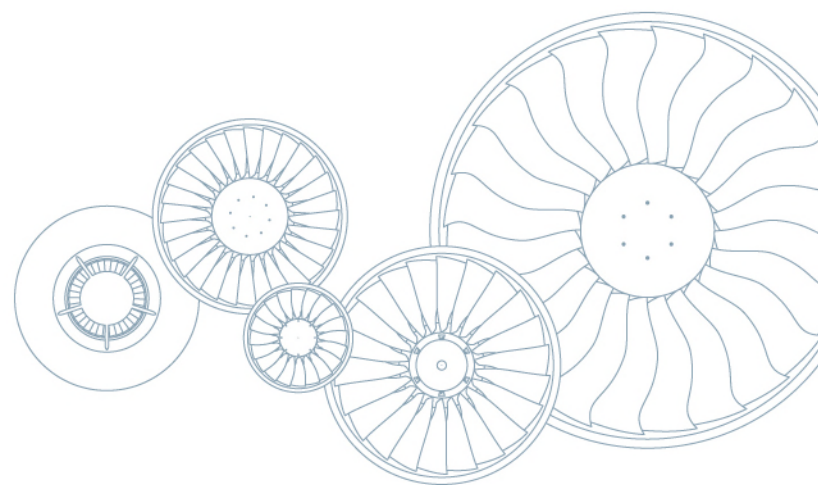

## Paris Air Show - Analyst Lunch Meeting

Le Bourget – June 19, 2013



## Contents

1. Market Overview / Revenue target 2020

---
2. Commercial OEM Business

---
3. Military Business

---
4. Commercial MRO

---

## MTU on track for 2020

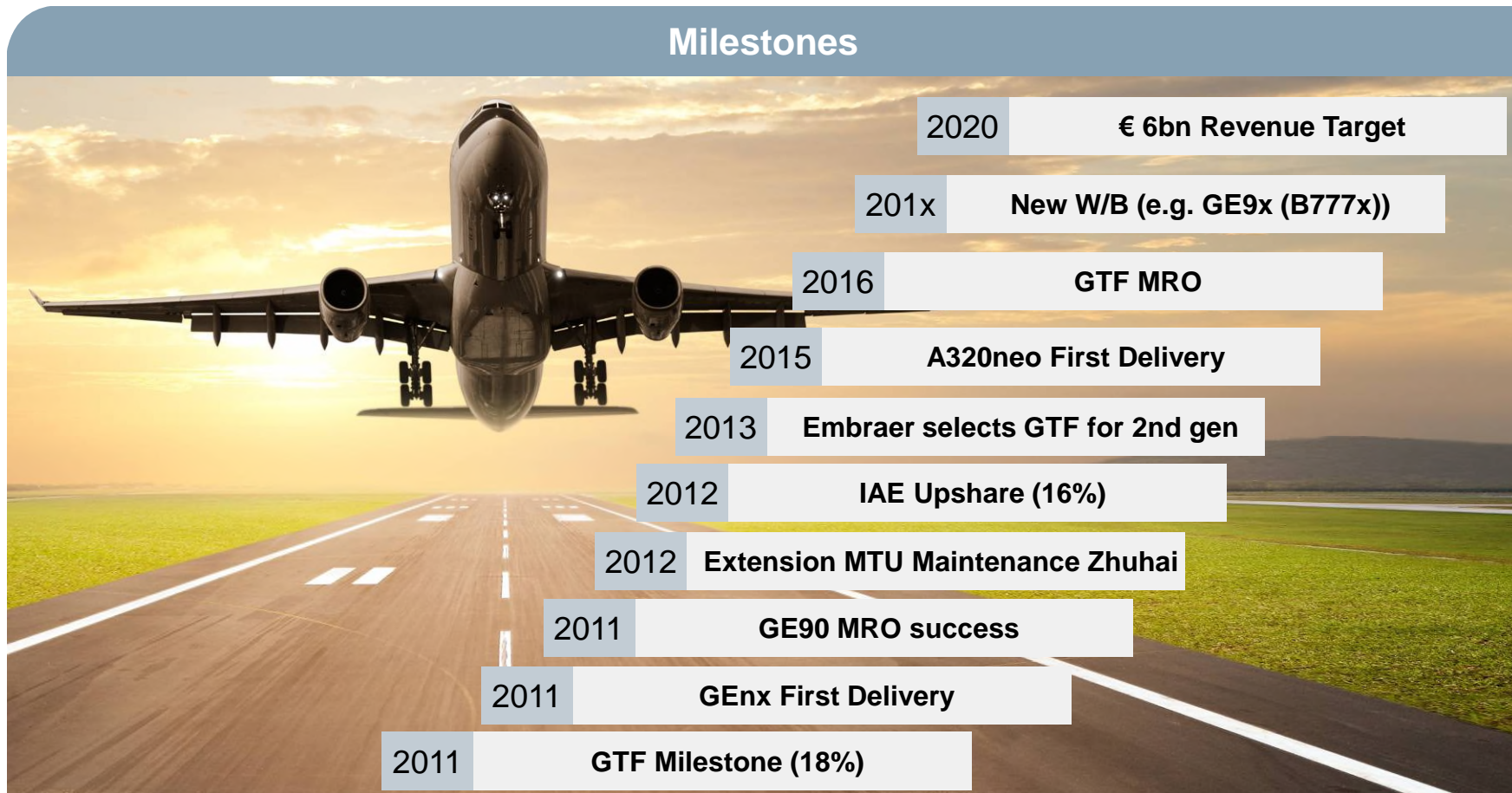

## The market cycle

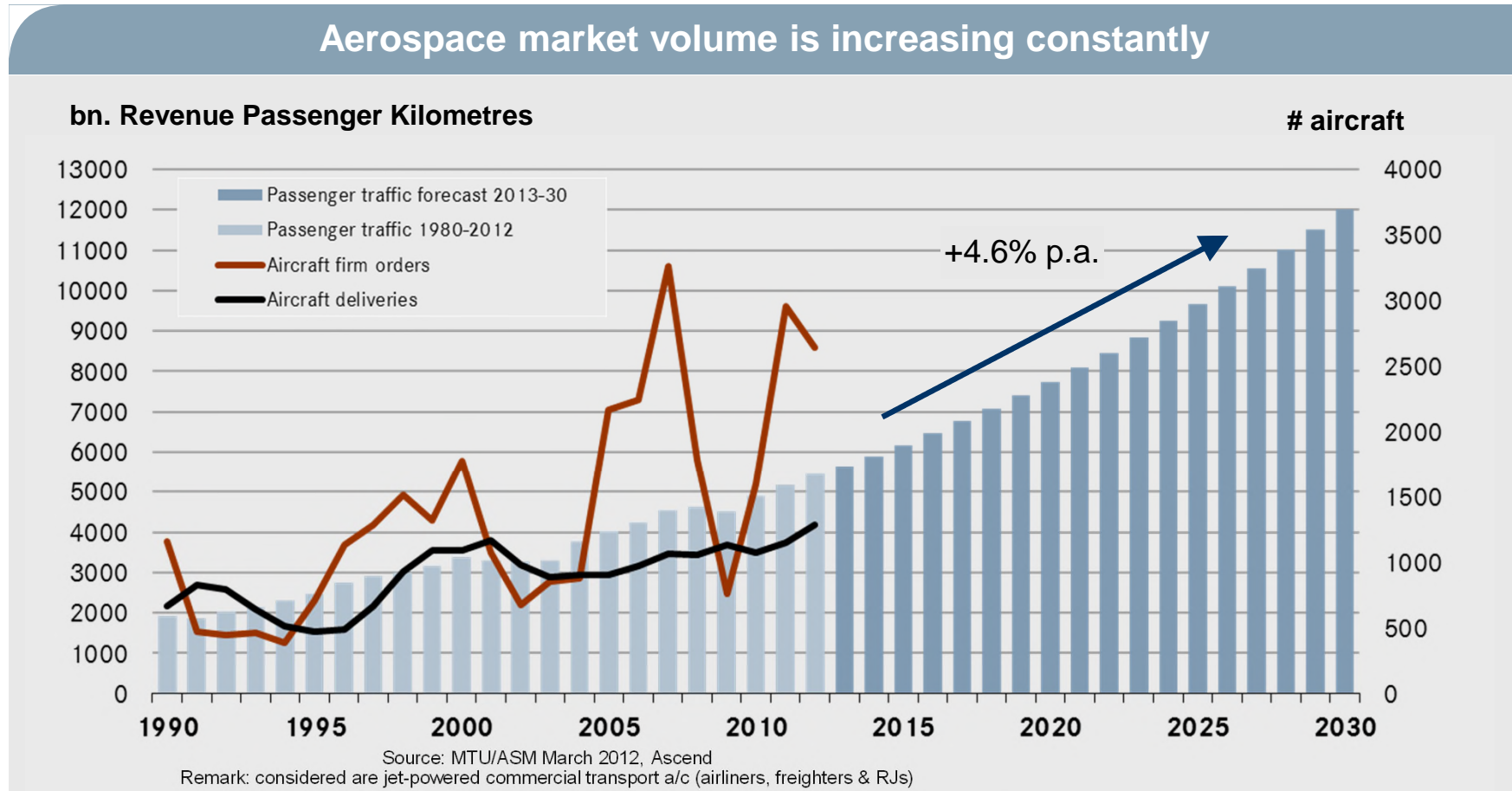

**Airbus expects more than 27.000 new passenger aircraft from 2012 until 2031**

## Strategic Revenue Target of € 6 bn until 2020

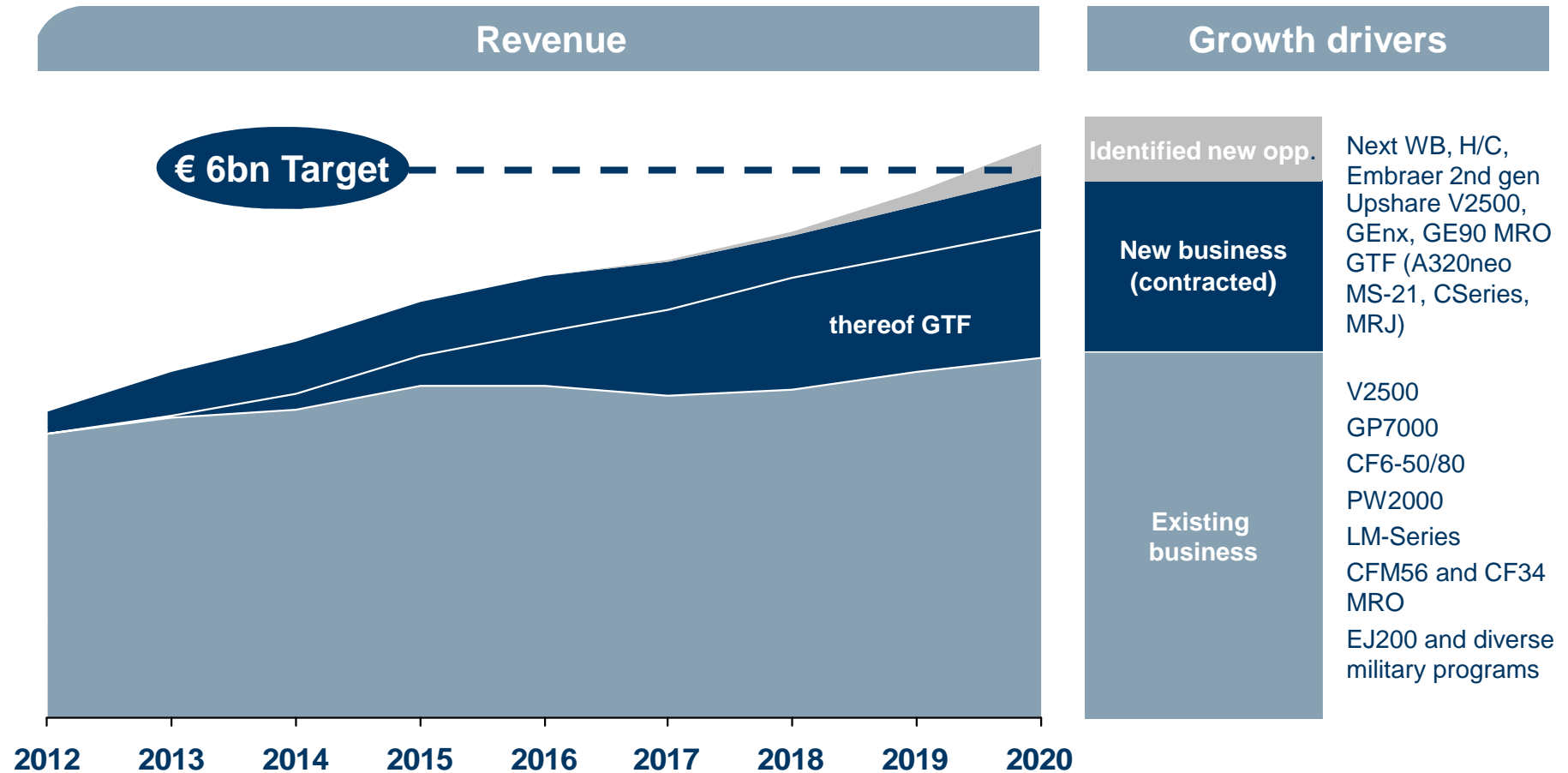

## MTU Narrowbody Strategy

	Today	2020	2025
<b>V2500</b>	OEM: 16%	Fleet in 2020 <b>~6,500 engines</b>	
	MRO: ~30%		
<b>CFM56</b>	MRO: ~8-10%	Fleet in 2020 <b>~20,000</b>	
<b>GTF Prog.</b> (PW1500G, PW1200G, PW1100G, PW1400G)	OEM: 15-18%	Fleet in 2020 <b>~4.000</b>	
	MRO: tbd		
		<b>PW1700/1900</b> (E-Jet 2 <sup>nd</sup> Gen)	OEM: tbd
			MRO: tbd

## MTU Widebody Strategy

	Today	2020	2025
<b>CF6-80</b>	<div style="border: 1px solid black; padding: 2px;">OEM: ~6%</div> <div style="border: 1px solid black; padding: 2px;">MRO: ~10%</div>	<b>Fleet in 2020</b> <b>~2,500 engines</b>	
<b>GE90</b>		<div style="border: 1px solid black; padding: 2px;">MRO: ~10%</div> <b>Fleet in 2020</b> <b>~2,000 engines</b>	
		<div style="border: 1px solid black; padding: 2px;">OEM: 22%</div> <div style="border: 1px solid black; padding: 2px;">MRO: &gt;10%</div> <b>Fleet in 2020</b> <b>~1,000 engines</b>	
		<div style="border: 1px solid black; padding: 2px;">OEM: 7%</div> <div style="border: 1px solid black; padding: 2px;">MRO: tbd</div> <b>Fleet in 2020</b> <b>~2,000 engines</b>	
			<div style="border: 1px solid black; padding: 2px;">OEM: tbd</div> <div style="border: 1px solid black; padding: 2px;">MRO: tbd</div>

## Commercial OEM Segment

MTU is well positioned in key growth platforms

- GTF engine family:
  - ~ 3,500 GTF engines on firm order or optioned (*incl. unannounced orders*)
  - Market share PW1100G (A320neo) ~50%
  - Program share on E-Jets in final negotiation
- Blisk manufacturing center at MTU Munich has been opened and is producing first parts
- V2500:
  - Strong aftermarket growth potential
  - IAE upshare implemented and well on track
- GEnx:
  - B787 fleet in the air again
  - No impact on production schedule
  - 1,400 GEnx engines on order or optioned
- Discussions with GE regarding GE9x participation ongoing





## GTF Success Story:

- ~ 3,500 engines on order (incl. options and unannounced orders)
- ~ 50% market share on A320neo / providing power for 5 platforms

PW1100G/ A320neo	PW1200G/ MRJ	PW1400G/ MS-21	PW1500G/ CSeries	PW1700G, PW1900G/ E-Jet 2 <sup>nd</sup> Generation
Lufthansa IndiGo  CIT ALAFOO  FLY SMART  GO AIR jetBlue  QATAR AIRWAYS 復興航空 TransAsia  ILFC CEBU PACIFIC AIR.COM norwegian.no	ANA TSH TRANS STATES HOLDINGS ANI SkyWest AIRLINES®	CRECOM™ nordwind airlines Ilyushin Finance Co VEB LEASING Rostekhnologii	Lufthansa LEASE CORPORATION INTERNATIONAL REPUBLIC AIRLINES MALMÖ AVIATION vi byr oss. atlasjet Ilyushin Finance Co  PrivatAir airBaltic	

## GTF Development Tasks on Track

PW1100G completed successfully first flight test on B747 in May 2013

Engine/ Aircraft	PW1100G/ A320neo	PW1200G/ MRJ	PW1400G/ MS-21	PW1500G/ C-Series	PW1700G, PW1900G/ E-Jet 2 <sup>nd</sup> Gen.
					
First Engine to Test	✓ ✓*	✓	Apr. 2014	✓ ✓*	Sep. 2016 Jan. 2015
Engine Certification	Jul. 2014	Dec. 2014	Aug. 2015	✓	Jul. 2017 Okt. 2015
EIS / Aircraft Certification	Okt. 2015	Sep. 2016	Jul. 2017	Jun. 2014	Starting Jun. 2017

\*) already tested in flying testbed

## Military OEM Segment

Stable revenues expected

### TP400 (A400M):

- 1st A400M series aircraft to be delivered to France in Q2/2013
- Ramp up of series production

### EJ200 (Eurofighter Typhoon):

- EJ200 Tranche 3a secures production until 2017
- Various export campaigns running



## Commercial MRO Business

Commercial engine MRO market expected to double to US\$ 37 bn in 2022

MTU market coverage grows over-proportionally

- Contract volume > US\$ 7 bn
- Participating in growth platforms: GE90 Growth, V2500-A5, CFM56-5B/-7, CF34-8/-10E, GP7000 and PW1000G
- Aviation Week's MRO Global Award for successful ramp up of GE90 Growth shop visits
- MTU Zhuhai's capacity increase by 50% to 300 shop visits p.a. successfully completed and ramp-up ongoing
- New Logistic Center at MTU Maintenance Hannover opened in March to improve processes and costs





Thank you for your attention!

